

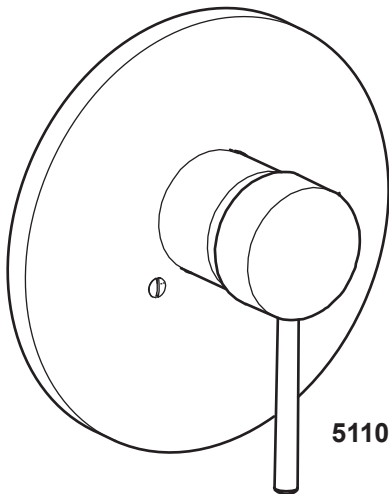

HANSAMIX / HANSAPRADO / HANSASTECLA

Montage- und Bedienungsanleitung • Mounting- and operating instructions
Instructions de montage et d'utilisation • Instruccion de montaje y de uso

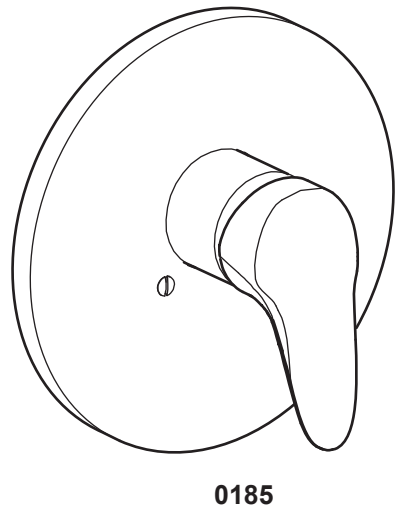
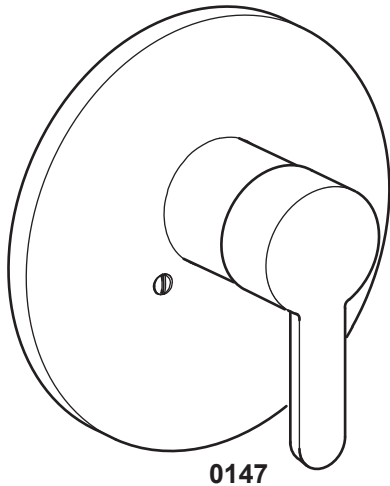

A020026/0707

HANSA Metallwerke AG

P. O. BOX 81 02 40 • D-70519 STUTTGART
SIGMARINGER STRASSE 107 • D-70567 STUTTGART
PHONE: (0711) 16 14 - 0 • TELEFAX (0711) 16 14 - 368
info@hansa.de / www.hansa.com

HANSA AMERICA Inc.

1770 Corporate Drive # 580
Norcross, GA 30093
PHONE: 678 334 2142 • FAX: 678 334 2148
www.hansanew.info

HANSA Produkte sind ausschließlich durch einen sanitären Fachhandwerker zu montieren.

HANSA products may only be fitted by a licensed plumber.

Les produits HANSA doivent être montés exclusivement par un artisan spécialisé en sanitaires.

Los productos HANSA deben ser montados exclusivamente por un técnico especialista en instalaciones sanitarias

Zur Einhaltung der Geräuschwerte nach DIN 4109 sind bei höheren Drücken als 6 bar Druckminderer in die Hauptleitung einzubauen

In order to keep noise level DIN 4109 it is recommended to install pressure reducing valves in case supply pressure is higher than 6 bars.

Pour respecter les valeurs de bruit selon la DIN 4109 des réducteurs de pression sont à installer quand la pression de service dépasse 6 bars.

Para respetar los niveles de ruido según la norma DIN 4109, debe instalarse un reductor de presión cuando la presión de servicio es superior a 6 bars.

Achtung! Bei Frostgefahr Hausanlage entleeren.

Attention! Drain system completely if danger of frost.

Attention! En cas de risque de gel, vidanger l'installation d'immeuble.

¡Atención! En caso de peligro de hielo, purg la instalación de agua, o bien vaciar las tuberías.

Achtung! Vor Einbau der Armatur Rohrleitung gut spülen

Attention! Flush pipes completely before installing faucet

Attention! Avant la pose du mitigeur purger l'installation

Atención! Antes de colocar el monocomando limpiar la instalación

Achtung! Allgemein anerkannte Regeln der Technik sind einzuhalten.

Attention! Please observe any recognized general technical rules.

Attention! Prière de respecter les règles générales de la technique reconnues

¡Atención! Se tienen que observar las reglas generales reconocidas de la técnica.

Achtung! Schäden, die infolge unsachgemässer Behandlung, natürlicher Abnutzung oder zu grosser Inanspruchnahme entstanden sind, sind von unseren Garantieleistungen ausgeschlossen

Attention! Damage caused by incorrect handling, natural wear, or applying too much force is excluded from our warranty provisions!

Attention! Les dommages intervenus suite à une manipulation incorrecte, à une usure normale ou à une sollicitation excessive sont exclus de nos prestations de garantie!

¡Atención! ¡Daños ocasionados por un manejo inapropiado, desgaste natural o una mayor utilización están excluidos de nuestra garantía

Einbaumaße

Installation dimensions

Dimensions d'encastrement

Dimensiones de instalación

0185

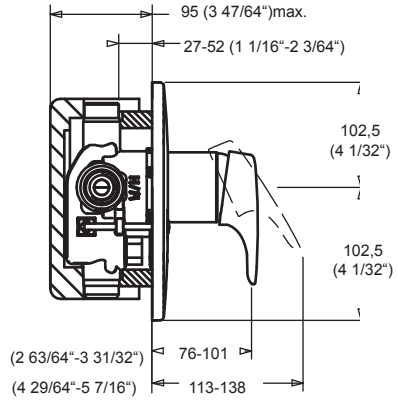
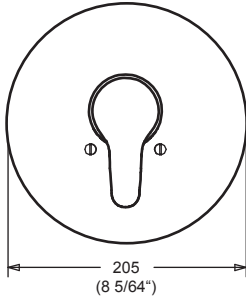

5110

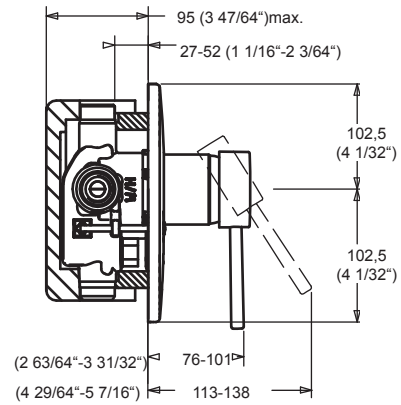
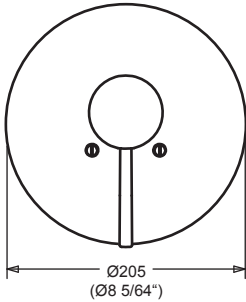

0147

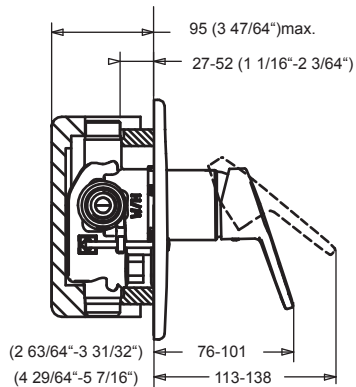
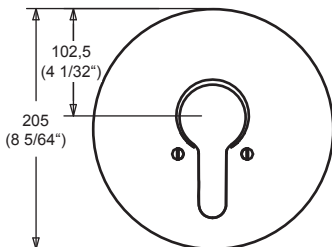

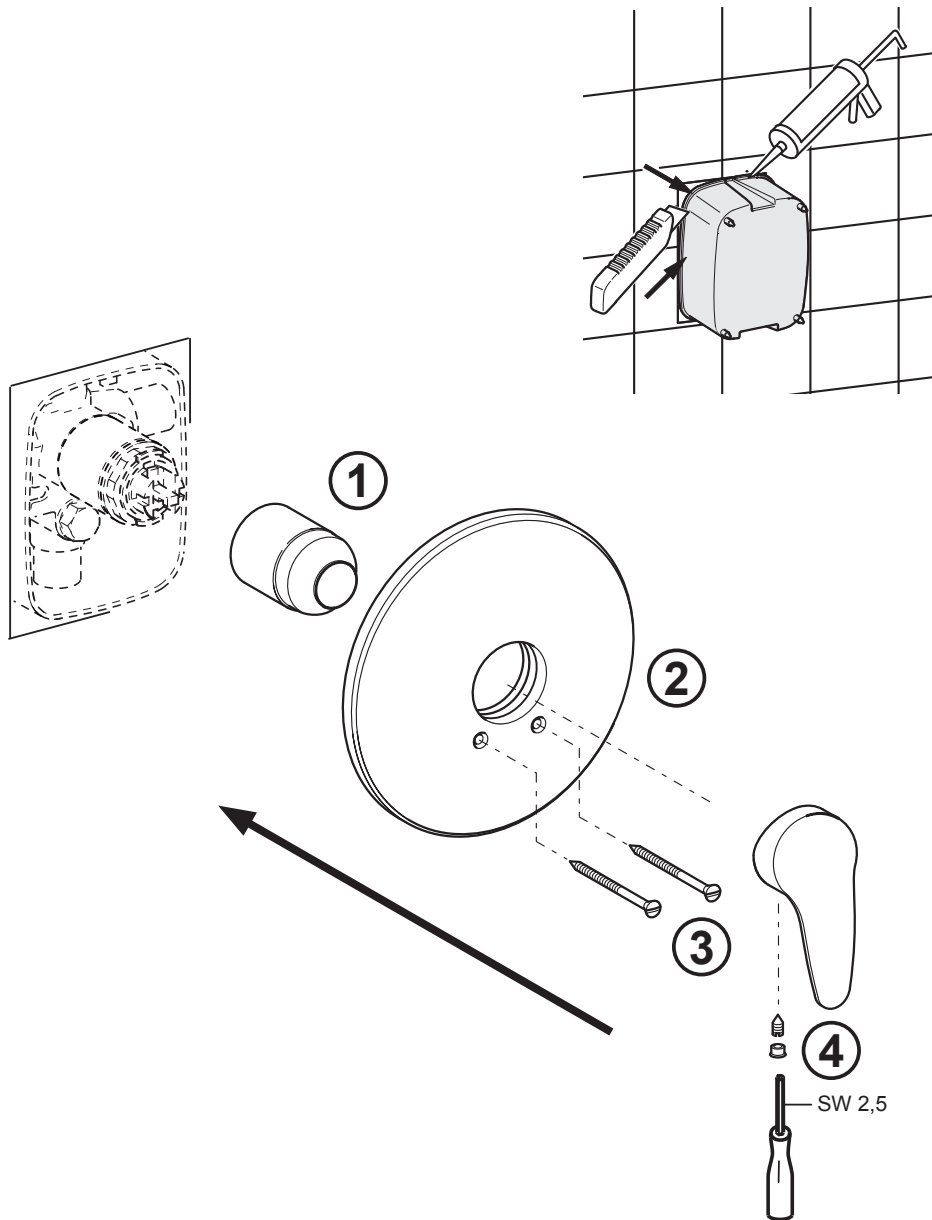

Technische Änderungen vorbehalten

Subject to technical alteration

Sous réserve de modifications techniques

Nos reservamos el derecho de efectuar modificaciones técnicas

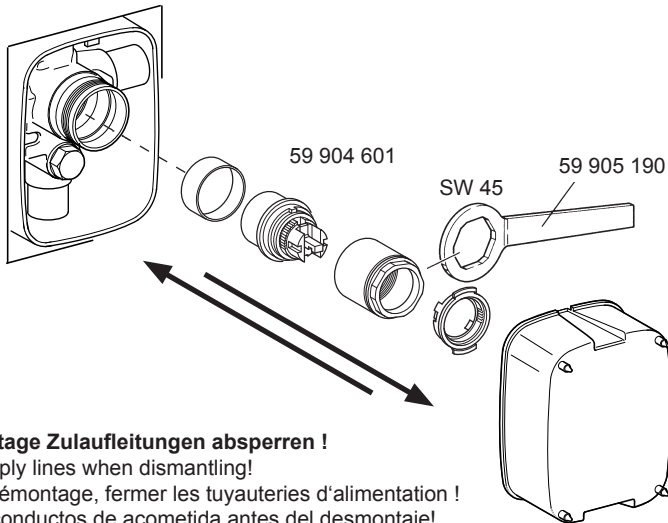

Bei Demontage Zulaufleitungen absperrn !

Shut off supply lines when dismantling!

En cas de démontage, fermer les tuyauteries d'alimentation !

¡Cierre los conductos de acometida antes del desmontaje!

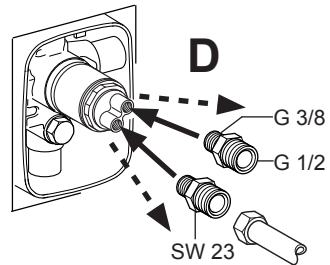
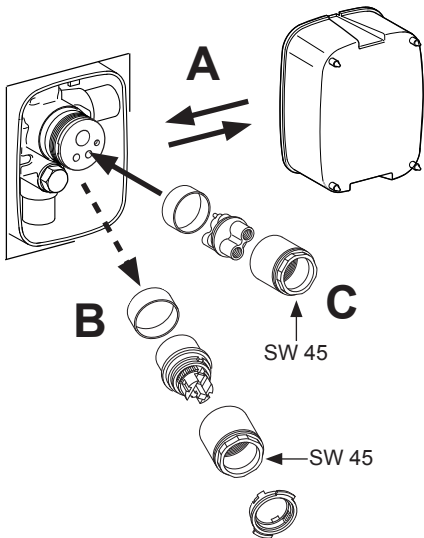

Spülen nach DIN 1988

mit HANSA-Spülstutzen 59 912 299

Rinse accordance to DIN 1988

with HANSA rinse pipes 59 912 299

Rincer selon DIN 1988 avec tubulures

de rinçage HANSA 59 912 299

Enjuague según DIN 1988 con

tubuladura de enjuague HANSA 59 912 299

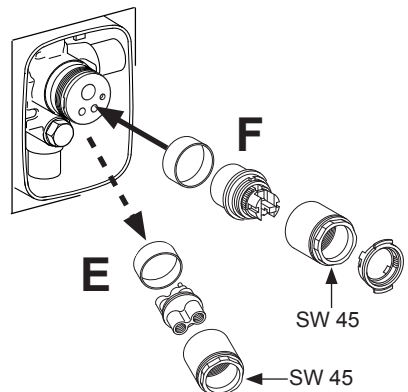

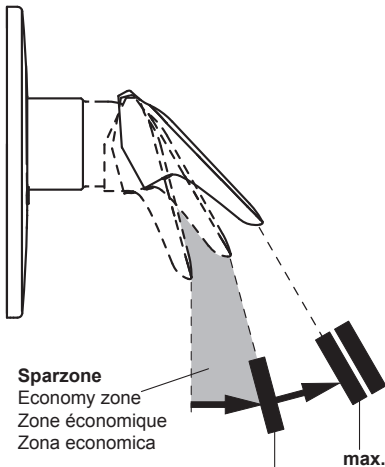
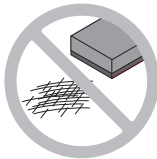
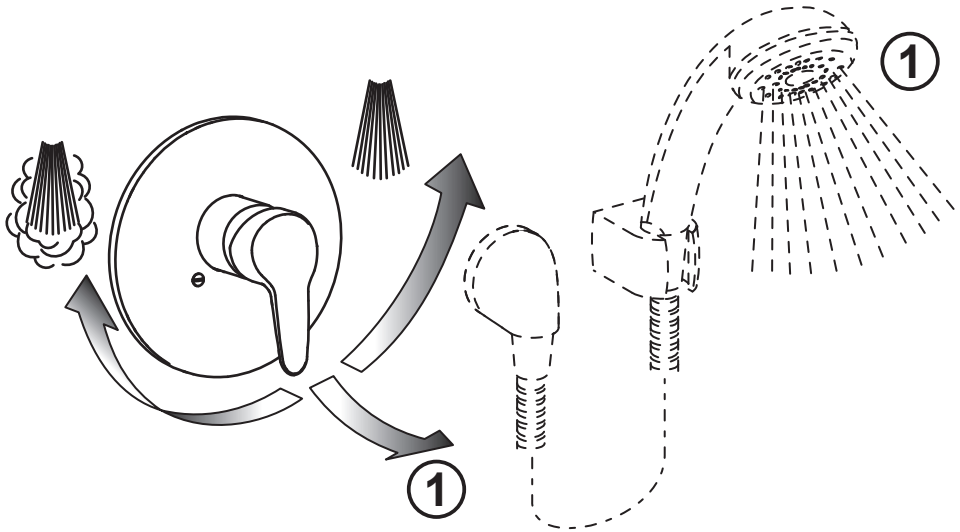

Achtung! Bei nachlassender Wassermenge Luftsprudler bzw. Brausen entkalken.
Bei anderen Störungen Ihren Installateur anfordern.

Attention! If water volume decreases, decalcify aerator/nozzle.
In event of other failures, call your plumber.

Attention! En cas de diminution du débit, détartrer l'aérateur ou la douchette.
Pour d'autres dérangements appeler votre installateur.

¡Atención! En caso de disminución del caudal de agua, descalcificar el aireador y la teleducha.
En caso de otros fallos avisar al instalador.

Wasserbremse
Waterbrake
Point contrôle de consommation
Punto de consumo limitado

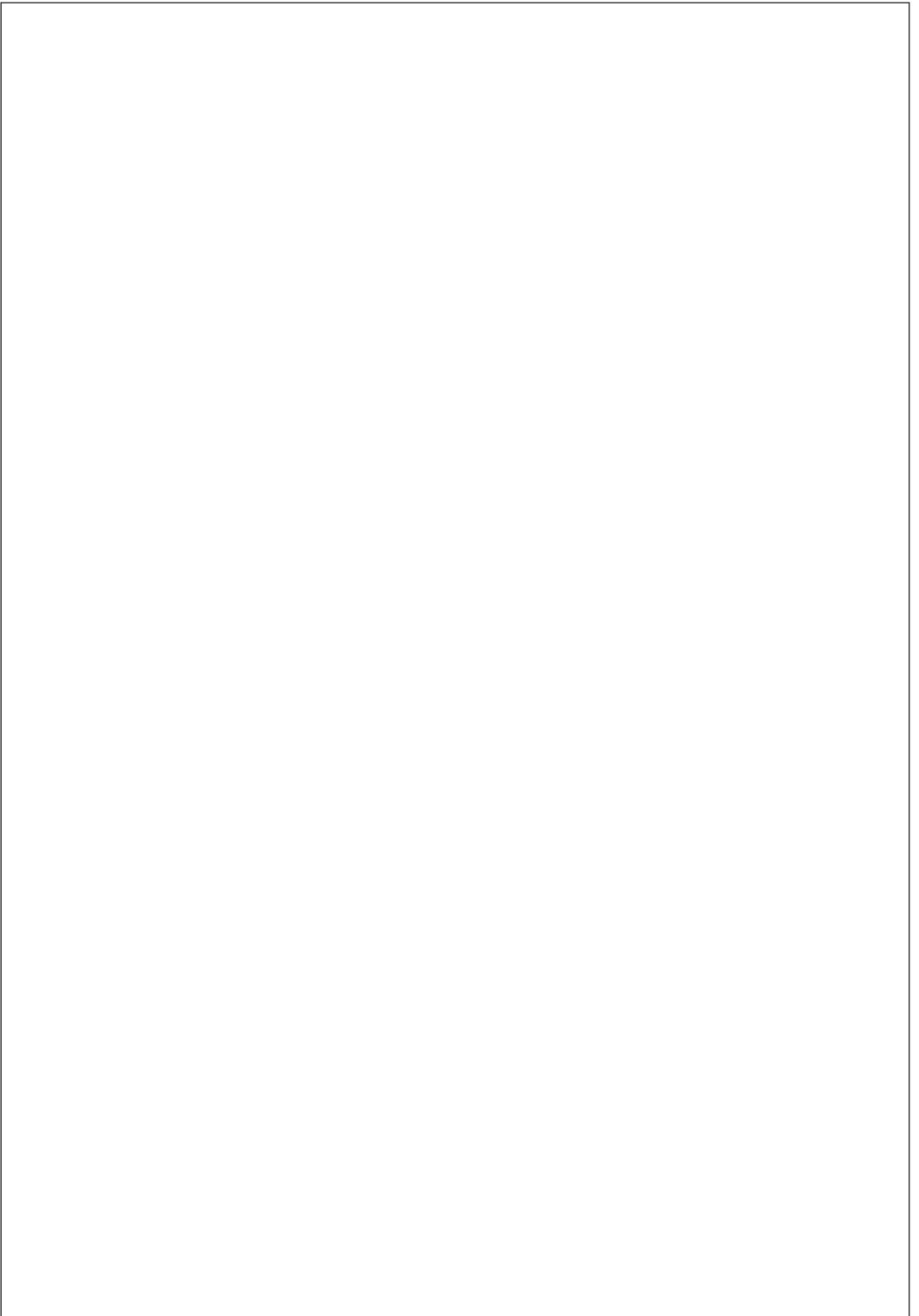



Pflegeanleitung für Hansa-Armaturen

Sehr geehrter Kunde, mit dieser Hansa-Armatur haben Sie ein Qualitäts-Produkt erworben. Um die Schönheit der hochwertigen Oberfläche zu erhalten, sind folgende Hinweise zu beachten: **Chrom, chrom-edelmatt und farbbeschichtete Oberflächen** sind empfindlich gegen säure- und sandhaltige Reinigungsmittel sowie kratzende Schwämme.



Achtung!

Farbige Oberflächen erfordern eine besonders sorgfältige Behandlung bei Einbau und Benutzung. Farbabweichungen bei farbbeschichteten Oberflächen sind verfahrensbedingt.

Pflege:

Bei Verschmutzung oder Verkalkung, Armaturen mit Seifenwasser oder verdünntem Haushaltsessig reinigen, mit klarem Wasser nachspülen und trockenreiben. Farbige Oberflächen nicht mit alkoholhaltigen- oder Desinfektions-mitteln behandeln. Pflege wie oben. Schäden, die durch unsachgemäße Behandlung entstehen, unterliegen nicht der Hansa-Gewährleistung.

Care and maintenance instructions for Hansa faucets

Dear Customer,

you have purchased a high quality product, and to maintain its beautiful appearance for a long time to come, we suggest that you care for it as follows: **Chrome, velvet chrome and colour coated surfaces** are sensitive to cleaning agents containing acids or abrasives as well as abrasive sponges.



Important!

Colour coated surfaces require extra care during installation and use. Slight colour variations can occur with colour coated faucets as a result of unavoidable process variations.

Maintenance:

Dirt and surface calcination are best removed with soapy water, followed by rinsing with plain water and drying. Avoid exposure of colour coated surfaces to disinfectants or cleaning agents containing alcohol, and treat such surfaces as described above.

Careless treatment of faucets invalidates Hansa guarantee provisions.

Conseils d'entretien de notre robinetterie

Cher client,

avec cette robinetterie, vous avez acquis un produit de qualité, et afin de préserver la beauté de la surface, veuillez bien suivre nos conseils.

Surfaces chromée, chromée-mat et traitements de couleur: Eviter les acides et les produits contenant du sable, ainsi que les éponges rugueuses.



Attention!

Les traitements en couleur demandent une manipulation très soignée au montage et lors de l'utilisation. Une légère différence de nuance est possible lors du traitement.

Entretien:

En cas de salissure ou de dépôt de calcaire, nettoyer avec de l'eau savonneuse. Rincer avec de l'eau tiède et essuyer. Les pièces traitées ne doivent pas être nettoyées avec des produits contenant de l'alcool, ou des produits désinfectants. Entretien comme décrit ci-dessus.

Les dommages dus à une utilisation non conforme à ces conseils ne sont pas couverts par la garantie.

Consejos para el mantenimiento de nuestra grifería

Con esta grifería, Ud. ha adquirido un producto de calidad. Para conservar impecable su superficie, deberá seguir nuestras instrucciones:

Superficies cromada, cromada-mate y tratamiento de color: Evitar los ácidos y los productos que contienen arena, así como las esponjas ásperas.



¡Atencion!

Los tratamientos en color requieren una manipulación muy cuidadosa en el montaje y en su empleo.

Limpieza:

En caso de suciedad o sedimento calcáreo, lavar con agua jabonosa. Enjuagar con agua tibia y secar. Las piezas en color no deben limpiarse con productos que contengan alcohol o acetona, ni con productos desinfectantes. Los daños o averías debidos a una utilización no conforme con estas instrucciones no están cubiertos por la garantía.

WARRANTY

KWC AMERICA INC. (A company of the HANSA Group) extends the following warranties to the original purchaser of the HANSA product effective August 1, 2007.

RESIDENTIAL INSTALLATION: Except as specified in this paragraph all products installed in a private residence will carry a LIMITED LIFETIME WARRANTY on all mechanical parts to be free of manufacturing defects in material and workmanship under normal usage. All chrome products carry a LIMITED LIFETIME WARRANTY on the finish. HANSA faucets with LED lights carry a 5-year warranty on the LED.

MARINE/OUTDOOR INSTALLATION: All products in a marine or outdoor installation are warranted to be free of manufacturing defects in mechanical parts and the finish for a TWO YEAR (2) period from the original date of purchase. Products and parts replaced during this period are warranted only for the period remaining in the initial two year period. The warranty does not apply if the product is misused or abused through negligence of the owner.

COMMERCIAL INSTALLATION: All products in a commercial installation will be warranted by KWC for a ONE YEAR (1) period from the original date of purchase. Products or parts replaced during this period are warranted only for the period remaining in the initial one year warranty.

KWC will repair or replace at its option any part or finish that is determined to be defectively manufactured under normal & proper usage and service during the above warranty periods. All products shall be returned prepaid to KWC's headquarters in Norcross, Georgia.

This warranty does not cover installation or any other labor charges. It will not apply to any products that have been altered in any way unless previously authorized in writing by KWC. Damage or misuse of the product for purposes other than for what it was designed are not covered. Faulty installation or maintenance is also excluded from this warranty.

This warranty is limited solely to the above statements, and this warranty and any warranties implied by state law will apply only for the periods herein specified. KWC will not be held liable for any loss, damage or expense, incidental or consequential damages of any kind whether based on warranty, contract or negligence arising in the sale, use or repair of the product. Some states do not allow for the exclusion or limitation on how long an implied warranty lasts, so the above limitations or exclusions may not apply. This warranty gives you specific legal rights, and you may also have other rights which may vary from state to state. Unless otherwise contrary to state law governing the purchase, KWC's liability will not exceed the contracted price for the product claimed to be defective or unsuitable.

To obtain warranty repair parts or replacement, simply write:

KWC AMERICA INC.

1770 Corporate Drive #580

Norcross, GA 30093

e-mail: techsupport@kwcamerica.com

Please include the model of the faucet and proof of purchase.

